

## Valve Installation Procedure

1", 1.5" & 2" Valves - Wafer and Threaded

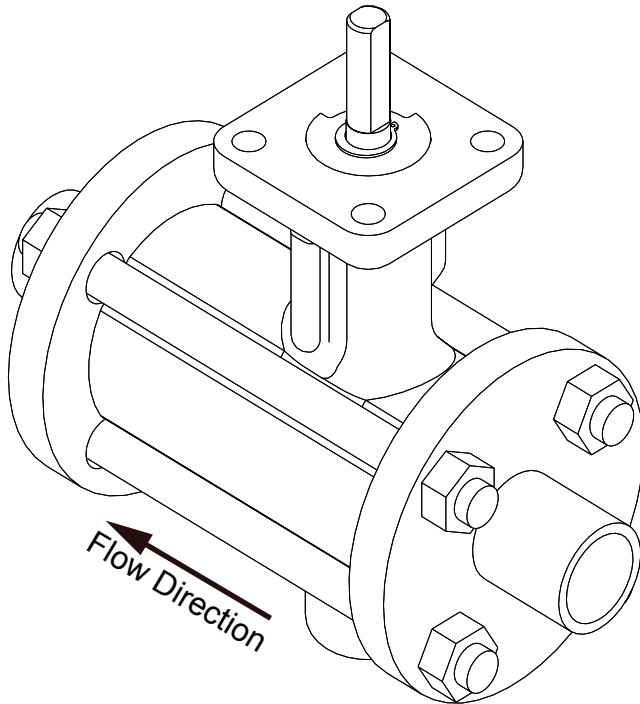

FIGURE 1

1. Figure 1 illustrates a wafered installation
2. Use All-Thread and hex nuts to secure the valve between flanges
3. Ensure proper gaskets are used between the valve and flanges
4. Tighten nuts in an alternating pattern

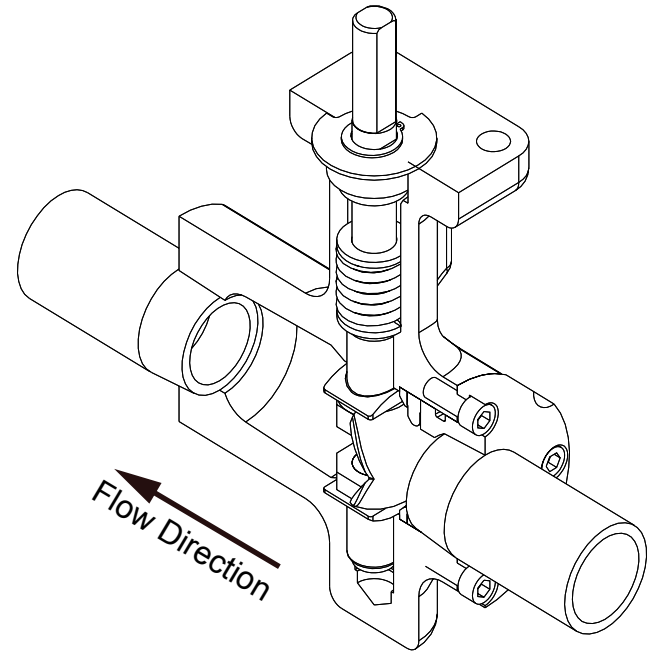

FIGURE 2

1. Figure 2 illustrates a threaded installation
2. Use 1", 1.5" or 2" NPT pipe
3. Ensure 4-5 wraps of Teflon tape on the pipe threads
4. Screw pipe into the threads of the valve

## Seat Replacement Procedure

1", 1.5" & 2" Valves

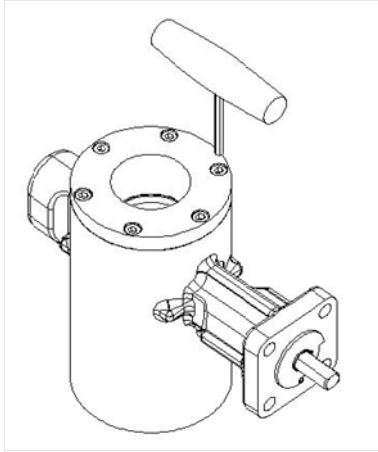

FIGURE 1

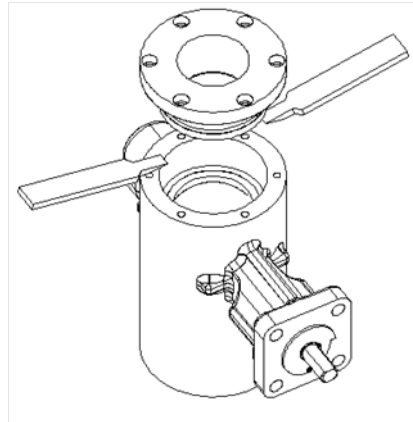

FIGURE 2

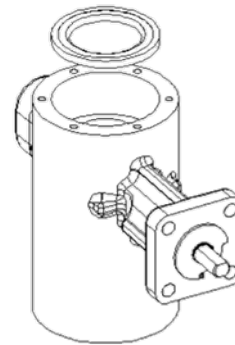

FIGURE 3

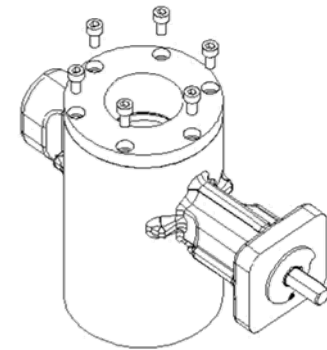

FIGURE 4

1. Remove the valve from the pipeline.
2. Unfasten the six (6) cap screws from the end of the valve (Fig. 1)
3. Remove the end flange using flat tools, or a pipe threaded into the end. (Fig. 2)
4. Rotate the ball to the open position. Remove the existing seat, then place the new seat in to the valve. Make sure there is no dust or foreign objects in the body or around the seat. This can cause the valve to leak. (Fig. 3)
5. Fasten the six (6) cap screws back into the end cap. Make sure that the cap end and the body are in full contact with each other. (Fig. 4)
6. Reinstall the valve into the pipeline.